

# **Seminar on FDI promotion in African countries**

**“ Strategic Action Initiatives  
for Economic Development :  
Strategies for Investment  
Promotion in Developing  
Nations**

**Venue: GRIPS Roppongi Camp**

**November 9th 2006**

**Dato' J. Jegathesan  
Senior Investment Adviser :  
Consultant to JICA and the  
Government of Zambia and the  
former Deputy Director  
General of the Malaysian  
Industrial Development  
Authority (MIDA)  
CEO - J J International  
Consultants**

# REALITY CHECK

- How is Africa (your country) perceived by others in respect of Investment Potential?
- What is the world global scenario of FDI flows on which Africa must depend upon?
- What are the lessons (in summary) that African Nations can learn from the Asian Experience?

Can South Nations (Africa) learn lessons  
from Asia?

Can South Nations (Africa) learn lessons  
from Asia?

## ONE Lesson: **LEADERSHIP** is the **KEY**.



- As CEOs of Companies forge Corporate Visions, Leaders of Nations must forge National Visions.
- Leader must be sensitive enough to feel the pulse and heartthrob of the nation and forge Visions that capture the imagination of all sectors.
- Leader must empower the people with the Vision so all feel that this is part of their Vision and all want to be part of the **MISSION** to realize **VISION**.

## MORE LESSONS...

**COMPARATIVE ADVANTAGE NOT THE KEY!**

Comparative Advantage of *Raw Materials* (Malaysia, Indonesia, Thailand) OR *Location* (Singapore, Hong Kong etc) are not enough.

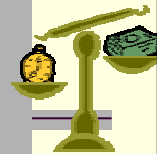

**Key is Competitive Advantage ...e.g. Rubber**  
1970s Malaysia – world largest producer / exporter yet world's largest exporter of

- Rubber shoes – Viking Askim in Scandinavia
- Rubber swimming caps -- Skellrup in New Zealand

**Yet within 1000 miles of NZ and Scandinavia – not a single rubber tree.**

---

**1970 – 1980 Malaysia focused not on RBI but labour and competitive advantage**

**After 1980 – Malaysia had both comparative and competitive advantage :- Viking Askim & Skellrup moved to Malaysia**

**All developing nations- to succeed- must focus on competitive advantage**

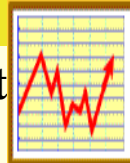

**In simple terms:-**

---

**Comparative Advantage**

**is conferred by God (i.e. Natural Resources / Location etc)**

**Competitive Advantage**

**Must be manifested by man to make full use of Comparative Advantage.**

For **Competitive Advantage**

To manifest –

---

**need for maximum cooperation,  
efficiency and incorruptibility  
among certain forces that  
initially make up a**

TRIANGLE OF HOPE

- In all Nations – the people, the citizen, the poor – look hopefully to a
- 

**TRIANGLE of HOPE**

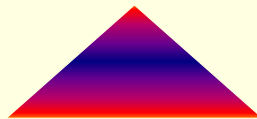

– to deliver jobs, opportunities, a decent life (wealth is a bonus).

# What is this Triangle of Hope?

- its world symbol should be

Political Will &  
Integrity



Civil Service Efficiency & Integrity



Private Sector  
Dynamism &  
Integrity

All Hope for  
**POLITICAL WILL & INTEGRITY:**



- 1) **Government leaders / Cabinet / Politicians/ Parliamentarians:** – who are selflessly dedicated to National development, are incorruptible. Have a vision for the future of their nation and see themselves as “gifted by God” to serve the Nation and its people selflessly.  
**Political Will** is the key word.

## CIVIL SERVICE EFFICIENCY & INTEGRITY:

- 2) **Civil servants** – who understand that they are “servants” of the people and not “Civil Masters”. They should be dedicated, incorruptible and totally apolitical, serving the Government in power and the people without fear or favour. **Civil service efficiency** is the key word.

## PRIVATE SECTOR DYNAMISM & INTEGRITY:

- 3) **Corporate / Private Sector** – who are dynamic, are aware of the problems of the nations, do not just wait for handouts, who realize that only if the common people are happy and prosperous that they too can succeed. Are also incorruptible and are prepared to work with the Government in power to achieve National Prosperity.

**Private Sector Dynamism** is the key word.

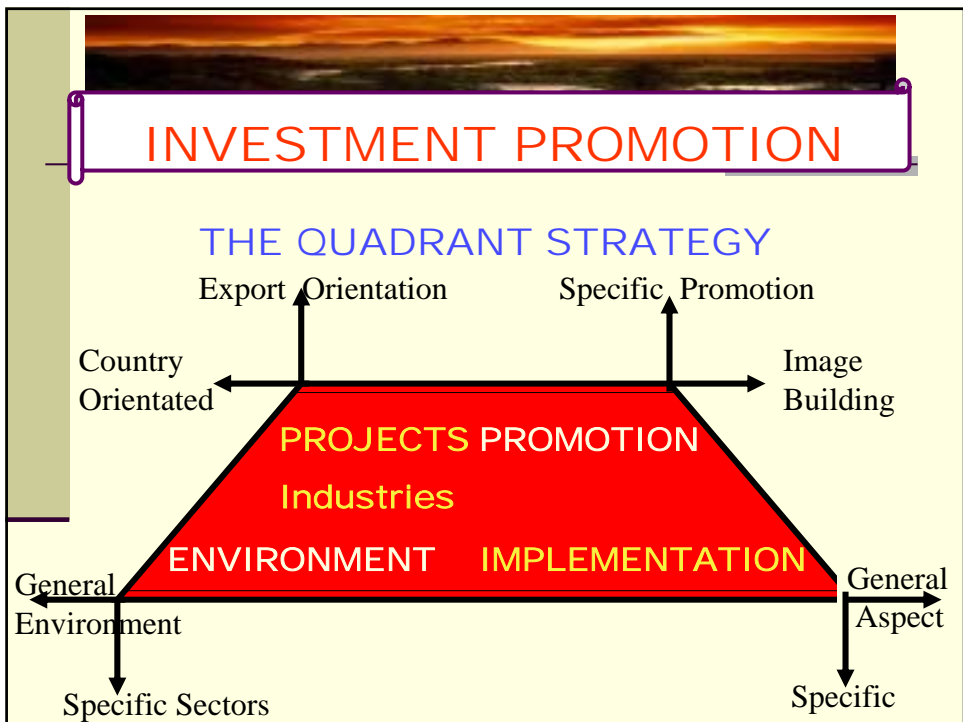



## Another MAJOR Lesson. Impact of GLOBALISATION.

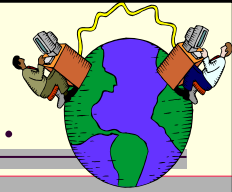

You either become a CENTRE OF EXCELLENCE for Manufacturing & Business...a super efficient “CBE” ... “CENTRE for BUSINESS EXCELLENCE”. Then even if small you can excel. (e.g. Switzerland, Belgium, Luxembourg, Hong Kong & Singapore.)

OR

You provide a Big Market by yourself OR by Regional Economic Groupings & a relatively efficient Business/Investment Environment e.g. Japan, S.Korea, China, Malaysia, Thailand, Indonesia and now ASEAN etc.

### **A Challenge!**

Can African Nations aspire to become CENTERS FOR BUSINESS EXCELLENCE?

- Many years ago (1970), Malaysia was in the same position in terms of Economic Backwardness.

Malaysia took the Challenge to become such a CENTER FOR BUSINESS EXCELLENCE.

I PRESENT HERE NOW A GLIMPSE OF THE MALAYSIAN STORY.



# The Malaysian Experience



...in Summary:

- Independence in 1957 from British Colonial Rule.
- Multi racial/ Religious Nation.
- Malays ( Muslims 50%), Chinese ( Christians, Buddhists etc 40% ) Indians & others (Hindus, Buddhists etc 10%)
- By 1965 Worlds largest exporter of Rubber, Hardwood Timber, Palm Oil, Tin, Pepper.
- ( Rubber from Brazil. Oil Palm from Africa)
- 1969...May 13<sup>th</sup>...RACE RIOTS devastated the nation.

## WHY DID IT HAPPEN?



- Rampant Unemployment
- Identification of Race with Economic Function.
- Imbalance in Wealth Distribution.
- FOREIGNERS : owned 60% of Corporate wealth.
- Malaysian CHINESE: 40% Pop....35%
- Mal. INDIANS & OTHERS: 10%....3%
- MALAYS: 50%...2% OF Corporate wealth.

**THE Government LAUNCHED A 20 YEARS OVERALL PERSPECTIVE PLAN (OPP) (1970 TO 1990) & NEW ECONOMIC POLICY (NEP)**

## Key Objectives of OPP & NEP

\*Create Jobs & Wealth

\* Redistribute Income and opportunities  
within context of a rapidly Expanding Economy.



- RESULTS?
- When we started our Big Push in 1970 Malaysia was a Raw Material Producer & did not have even ONE export Oriented Manufacturing Company.
- But 10 years later...in 1980 Malaysia had become:
- The Worlds Largest Producer of Electronic Semiconductors ( employing more than 150,000 people) &
- The 3<sup>rd</sup> Largest country in the world exporting Room Air conditioners.

## How was this possible?

- ▶ Certain elemental laws of nature guide natural forces on this earth and once Man recognizes these laws, he can tap these forces for benefit...
- ▶ Likewise Malaysia recognized the that certain elemental laws equally guide forces of Economics.
- ▶ We Recognized these laws and used them for our advantage.



# Elemental Law of Investment Flows :-

•Centrifugal  
(Push)  
Factor

•Centripetal  
(Pull)  
Factor

## **PUSH FACTOR**

At times in world economic history there are certain forces 'pushing companies' in capital and technology exporting nations to invest abroad – i.e become F.D.I.

### **Negative Forces**

- Increasing Costs of producing locally
- Increasing costs of electricity, water etc.
- Increasing costs of environmental protection
- Labour shortage and cost

### **Positive Forces**

- Expansion to new markets
- Company's drive to diversify
- Company wants to be close to raw material source
- Company wants to be closer to the overseas market or supplier
- Drive to take advantage of Regional markets e.g. ASEAN
- Company divides the world into strategic geographic areas

## **PULL FACTORS**

The PULL Factors can be put into a

## **Strategic Action Initiative Formula**

Or

## **S.A.I. FORMULA**

FAR EASTERN EXPERIENCE

FORMULA FOR SUCCESS

IN

Economic Development

$$E + C_4 + O = P$$

**Not Problems**

**P**

**Profits for Enterprises**

**Prosperity for the Nation**

**E**

$$E + C_4 + O = P$$

**Environment – THE 10 COMMANDMENTS**

**Or Check Points that every investor MUST observe**

- 1. Political Stability**
- 2. Economic Strength / Fundamentals**
- 3. Attitude of Welcome – from highest Minister to most junior civil servant and public**
- 4. Government policies**
  - a. Equity**
  - b. Employment of Expatriates**
  - c. Exchange control**
  - d. Rule of Law (Ownership of Assets etc)**

**E**

$$E + C_4 + O = P$$

**Environment – THE 10 COMMANDMENTS**

**Or Check Points that every investor MUST observe**

- 5. Infrastructure- land, Electricity, water etc..; Availability, Costs, Quality, etc.,**
- 6. Labour (Trainability, Education, Work Ethics, Harmony...all these spell one word PRODUCTIVITY)**
- 7. Banking & Finance**
- 8. Government Bureaucracy – friend & ally or hostile obstacles**
- 9. Local Business Environment**
- 10. Quality of Life**

In the 10 Checkpoints -  
No Mention of Incentives

Incentives are **CRITICAL**



But are the

Icing on the Cake!!



The 10 Checkpoints constitute the  
Solid Fruit Cake i.e. the company  
must make profits.

In a bakery- which would most people choose?  
The Cake without icing or the Cake with the icing...

**Investors do the same.**

$$E + C_4 + O = P$$

**C<sub>4</sub>**

- **Cost** of Doing Business
- **Convenience** provided at all stages
- **Capability** of the Infrastructure and Government Machinery
- **Concessions** (carrots) – Incentives, etc.,

$$E + C_4 + O = P$$



**Opportunities** – What opportunities does the country offer? Mining, Trading, Manufacturing, agriculture, etc., Is this available in Government or private sector publications? In short how will the investor know the opportunities for import substitution or Export orientation that the country offers.

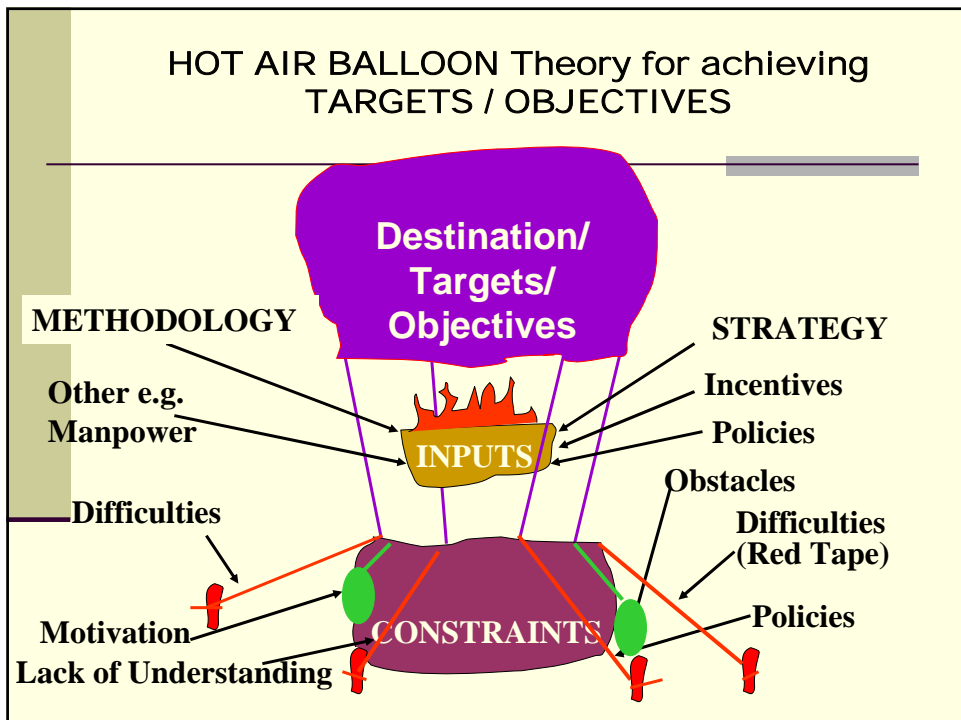

## THE DEVELOPING COUNTRY SYNDROM

Are you giving your investors a fighting chance?!!

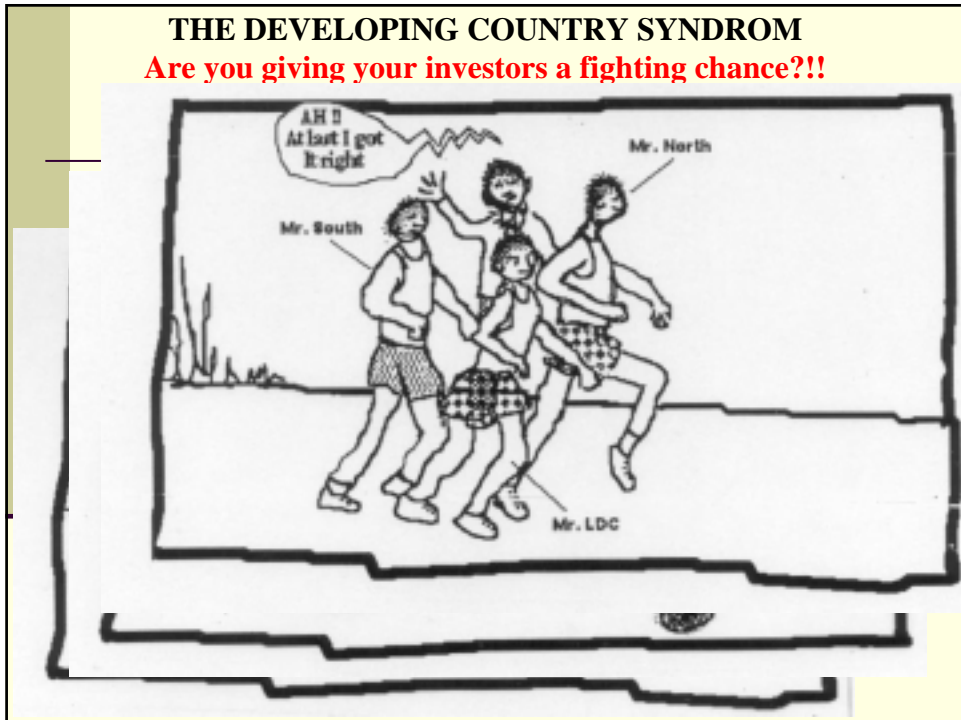

## AGENDA for ACTION



- ▶ Need for a strategic Plan of Action...based on a VISION of what you want your country to be.
- ▶ This Vision must come from Top leaders and the Civil Service and Private Sector (Business & Workers) must join forces to realize Vision.
- ▶ Not emotional nationalism but Strategic Action Initiatives designed for Short, Medium and Long Term Results.



# Emotional Nationalisms???



- 1) Why must foreigners come and make profits in my country?
- 2) Local people must own everything , Banks, Insurance etc. let foreigners take minority share?
- The lesson Malaysia learnt was this:
- Do we want to own 100% of 100
- OR
- 40% of 1000.
- The key is a dynamically expanding economy...
- So that Wealth & not Poverty is distributed.

RECOGNIZE THAT CURRENTLY  
3 Great Waves drive Economies of  
Nations

---

**1<sup>st</sup> Wave.** – Agriculture – slow moving- long term - **continue this initiative!**

**KEY: Cost efficiency & Productivity.**

**2<sup>nd</sup> Wave** – Industrial Development: must establish competitive advantage.

**Who are your competitors?**

**3<sup>rd</sup> Wave** – Service / Knowledge based drive....! Knowledge workers are driving World Economy.

## TECHNOLOGIES FOR SOUTH NATIONS FOR ECONOMIC SUCCESS

### Everybody is looking at ICT...BUT...

In looking at **ICT** (Information & Communication Technology) – African Nations should have a multi pronged strategy!

☐ **MCT** – Manufacturing & Creative Technology

☐ **ACT** – Agriculture & Commodity Technology

☐ **BCT** – Building & Construction Technology

☐ **FCT** – Finance & Currency Technology

ALL these Technologies will lead to EMPOWERMENT of South Nations!

**This is what Asia did!**

## VII) The Role of IPA.

*ONE KEY ELEMENT IN THE STRATEGIC ACTION INITIATIVE (S.A.I.) FORMULA IS....*



**The role of the National Investment Promotion Agencies (IPA)**

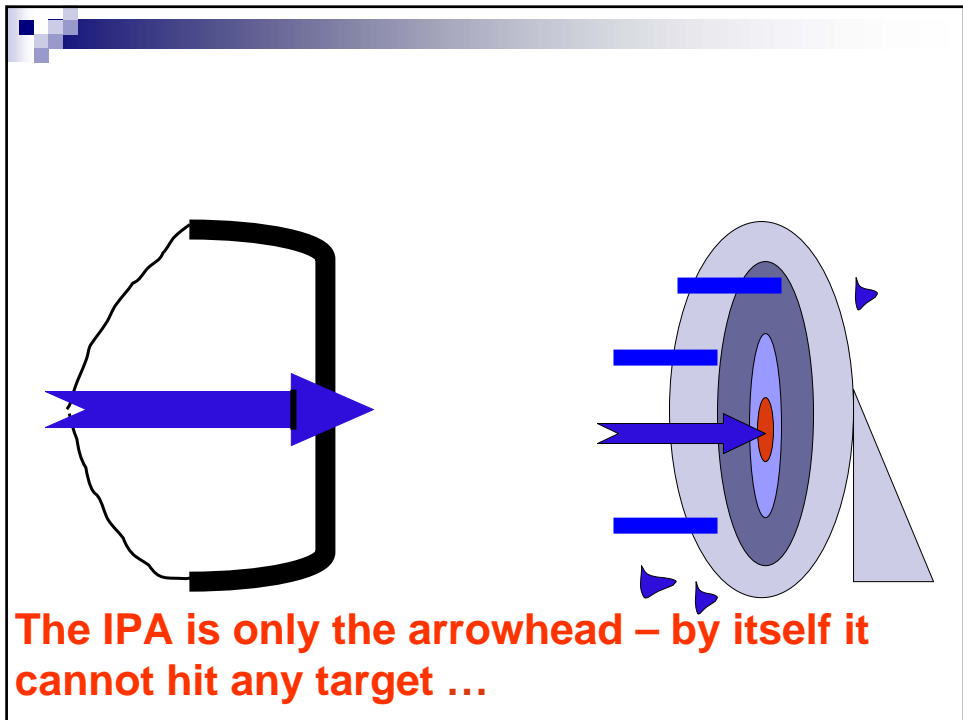
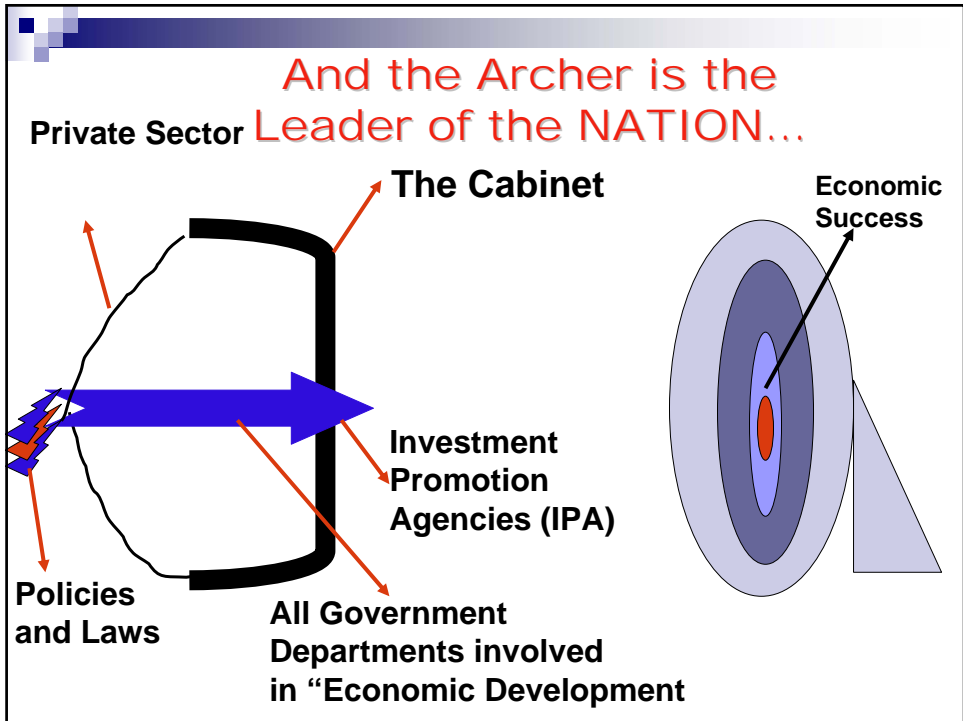

## What can AFRICAN Nations learn from the Asian experience?

- Let us examine a possible Action Agenda through the spectrum of the:

**TRIANGLE OF HOPE**



**THE QUADRANT STRATEGY!**

### IN RESPECT OF THE TRIANGLE OF HOPE

1) **POLITICAL WILL:** Briefing Sessions can be held for all Members of Parliament/Ministers (including Opposition members), on subjects relating to:

**STRATEGIC ACTION INITIATIVES FOR ECONOMIC DEVELOPMENT AND THE ASIAN EXPERIENCE (one example: Malaysia)**

(Malaysia, a multi racial Islamic nation, which became independent in 1957...about the same time as many African Nations, which in 1969, after the May 13<sup>th</sup> Race riots was written of as another "basket case" economy & what it is today, would make an ideal case study.)

**The objective of this ONE FULL DAY SESSION WITH Q&A, will be :**

**To help leaders who are making decisions about the future of their nation in a rapidly changing and competitive world to understand the Economic Process that drives Nation Building and the challenges of Globalization.**

**The session will help in some degree to make all Members of Parliament and Political Leaders realize:**



**# The critical role that FDIs can play in the process of Jobs and Wealth creation.**

## 2) The 2<sup>nd</sup> side of the Triangle of Hope relates to “Civil Service efficiency and integrity”!

- For Civil Servants, which will include all officers in the Investment Promotion Center and two or three TOP OFFICIALS from every Govt. Dept. involved in the Economic Process ( Customs, Immigration, Road Transport, Central Bank, Ministry of Finance etc)...a full 2 ½ to 3 day Capacity Building/Training session can be held.
- The title of the topic can be same as that for the MPs, but this Training session will go into depth on issues of coordination, streamlining etc.

In short whereas the MPs session will focus on **WHAT** should be done to achieve Economic Success, the Civil Servants session will address not just the **WHAT** but **HOW** it can be done.

- The lessons from Asia regarding **streamlining & capacity building** can be useful.
- The setting up of **INTEGRATED APPROVAL SYSTEMS** for every Govt. Dept., the streamlining of the approval mechanism at every level of the APROVAL PROCESS from National/Central Govt. to Municipality/City levels will be critical.
- The process must move from **KNOW WHO** to get an approval, to **KNOW HOW** and the strength of the project itself.
- There must evolve a **Systems Approach** in Govt. and one way would be to embrace “**e governance**” as a concept to drive efficiency and to reduce Red Tape and corruption.

# Integrated Approval Systems

- 1) Who are you serving?
- 2) Why?
- 3) Is the service you provide most efficient?
- 4) How to improve further?
- 5) Is your internal system fully integrated – (How can further integration be achieved).
- 6) Are you integrated with other Department?
- 7) Do you think that the service your Department provides has a role in Jobs & Wealth creation and Poverty Eradication?
- 8) What is it's role and how can maximum efficiency & productivity be achieved?

9) Which Government Departments do you think you are related to

(a) Directly      (b) Indirectly

- 10) Do you know that a chain is only as strong as its 'weakest' link?
- 11) In the chain of National Economic Development is your Department – a strong or weak link?
- 12) How to strengthen that link?
- 13) Do you know that though the chain is as strong as its 'weakest' link – that the Department Head is the link maker, the Minister & the Civil Service Head of Ministry make part of the chain and that the Head of State is the ultimate Chain maker?
- 14) How can you help the Minister and Head of State to create an unbreakable chain?

**(3) The 3rd Force in the Triangle of Hope is PRIVATE SECTOR DYNAMISM and INTEGRITY:-**

- Here it is proposed that a ONE Day briefing session be held for all the Captains of Industry on the similar basis as that of the MPs.
- The Topic title can remain:
- **STRATEGIC ACTION INITIATIVES FOR ECONOMIC DEVELOPMENT AND THE ASIAN EXPERIENCE**
- In addition the presentation could include issues relating to GLOBALIZATION, and some suggestions as to what the private sector can do to be prepared for these challenges.

**In respect of the Quadrant Strategy that encompasses INVESTMENT ENVIRONMENT, PROJECTS, PROMOTION AND IMPLEMENTATION interested African Governments can be helped to:**

- 1) Examine & assisted as to how the **Investment Environment** can be improved to attract FDI and to stimulate domestic investments.
- 2) Identify strategic **Industries/Projects** that can be promoted to maximize the competitive advantage that a country has to offer.
- 3) Launch **Investment Promotion** strategies/ programmes in target Asian CAPTEN Nations.
- 4) Ensure that that proper mechanisms are in place to ensure speedy **Implementation** of approved projects.



In addition to the above in a programme called “Agenda of Action”, the following should be undertaken:

- 1) To create a “FAMILIARITY THAT WILL BREED CONFIDENCE” among Asian Businessmen, interested African Governments should consider the following actions:
  - a) Organize with African private sector, buying and selling missions to target Asian nations.

This will create direct linkages between Asian and African Businessmen, **reduce the role of the middle man from other nations** and reduce the cost of Asian products in Africa.

Such increased business linkages will create the confidence for longer term Asian investments.

- b) Offer to Asian businessmen, opportunities to participate in the

**“Privatization and Development Projects (PDPs) the country has to offer.”**

- To implement this, the relevant African Governments should put together a package of PDPs and organize missions to target Asian nations.

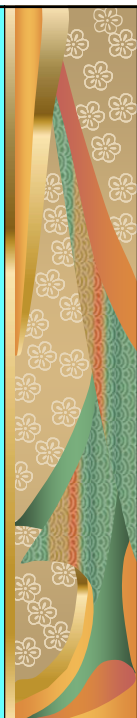

**c) Promote Asian Financial Institutions (Banks & Insurance) to set up operations, for these are the most powerful conduits for flow of Investment funds.**



**To ensure that the existing domestic & foreign private sector are an ally to Government's Promotion efforts, African Govts. can be helped to set up "Public-Private Sector Presidential Committees on Investments." ( PPS-PCI)**

**OBJECTIVE:** To create a happy , supportive, domestic Private Sector Group.

- 1) The President with Key Economic Ministers and Captains of Industry should meet, initially at least 2 or 3 times a year, and later as issues are addressed and solved these can be reduced to an Annual basis.**
- 2) The issue of meetings is not just to call a meeting and having it end as a "complaints session". The sessions should have considerable pre planning and preparations so that the Presidential meeting becomes highly productive.**

**The Asian Experience as to how these PPS -PCIs can be set up to become powerful tools for Investments, can be shared.**

**Key Question: Do African Govts. feel that they want to proceed on sustained, well planned strategies?**

**Also are International & National Donor Agencies prepared for such strategic steps that are sustained and results not as “Reports on a dust covered shelves”, but “Jobs and Wealth” on the Ground.**

**I have worked with many International Agencies since I retired from MIDA in 1999. All are sincere, but how many have gone beyond “Reports that end up on shelves”?**

## **Proposal for 3 Testbed Nations** **(The TRIDENT STRATEGY)**

- **Despite millions of dollars being poured into Africa, there is not one Economic Model that can be taken as a Success Story that others can emulate, unlike the multiple success stories in Asia, from Japan to Singapore, from Taiwan and South Korea to Thailand and Malaysia.**

- **I had suggested to many International Agencies, that whereas all nations be helped, 3 TESTBED Nations be selected to launch the full 3 to 5 year “S.A.I. for Economic Development” programme and that we work with these 3 Nations until we see Jobs and Wealth on the ground.**

The proposal was that 3 “Test Bed Models” be selected:

- **(a) A Land Locked Nation (e.g. Uganda, Zimbabwe, Malawi, Rwanda, Zambia etc)**
- **(b) A Nation with Coastline and a relatively large population.**
- **(c) An Island Economy.**

**I am proud to say that the Japanese Govt. through JICA accepted this challenge**

# The 1<sup>st</sup> Test Bed Nation is Zambia: Land Locked.

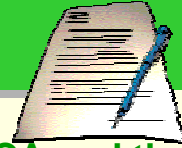

- 1) An MOU was signed between JICA and the Govt. of Zambia in March 2005 to launch what is now known in Zambia as the “Triangle of Hope” programme.
- 2) The Political Will has been tremendous:
  - The President has formed a Presidential Steering Committee chaired by the Deputy Secretary to the Cabinet and where the JICA Resident Representative is one of the 2 Deputy Chairmen.

- 3) Arrangements were made for the JICA consultant to brief Parliament and this briefing was well received by all parliamentarians.
- 4) The President has shown personal interest and he and his cabinet has been briefed on 3 occasions on the progress of the TOH agenda.
- 5) In keeping with the TOH formula the Govt. arranged a 3 day Briefing cum Workshop session on the TOH programme for Senior Civil Servants and also a session with the Private sector.

- **6) After fulfilling the obligations of the TOH the GoZ proceeded to fulfill the requirements of the Quadrant Strategy viz: Environment, Projects. Promotion & Implementation.**
- **7) 12 Govt. Private sector Task Forces were set up to look at issues relating to the Physical and Administrative Infrastructure, (Environment & Implementation), and Sectors that will have Competitive Advantage (Projects)**
- **8) The Task Forces were given a TOR and were briefed on expectations and given 3 months to present their reports.**
  - **This they did very effectively. All TF recommendations were submitted to Cabinet and have been approved.**

- **9) The GOZ, with JICAs assistance where necessary, is now involved in the Implementation of all Recommendations approved by Cabinet. A monitoring mechanism has been established and JICA is helping in this process.**
- **10) Having fulfilled to an extent the expectations of the Quadrant strategy we are now entering the Promotion phase.**
- **11) Project Profiles are being drawn up, initially focusing on existing companies that wish to expand, diversify or set up new projects. An Investment Booklet designed with the Potential Investor in mind is being prepared.**

- 12) A very focused Investment Seminar is being organized in Malaysia towards the end of Nov. 2006 and in March 2007 we are planning for a Malaysian Investment Mission to Zambia.

- 13) Since this is a Asia – Zambia South South Initiative, the promotion initiatives to other Nations in Asia will commence in the 2<sup>nd</sup> quarter of 2007.

- 14) It is the expectation, if all goes as planned and all recommendations of the TFs are fully implemented that Zambia should experience increased FDIs, increased JVs with Foreign Investors and increased Jobs and Wealth for the people of Zambia, in the next 2 to 3 years.

THE END .....

Thank You

**@ Copyright**  
**JJ International Consultants**

■ **Dato' J. Jegathesan**  
**No 24, Jalan Abdullah,**  
**off Jalan Bungsar,**  
**59000, Kuala Lumpur**  
**Malaysia.**

E-mail:- [jjegaic@yahoo.com](mailto:jjegaic@yahoo.com)

Website:- [www.jjegaic.com](http://www.jjegaic.com)